

STATION PARK
GREEN

SWC S Delaware St & Concar Ave
SAN MATEO

New Mixed-Use Development with 29,000 SF of Ground Floor Retail/Office Space



PROPERTY HIGHLIGHTS

- New mixed-use development including 599 apartments, 22,000 SF of retail space and 7,000 SF of office space
- Transit-oriented development built around the Hayward Park Caltrain Station
- Directly adjacent to 400/450 Concar, new office development with 305,000 SF of class-A space
- Dedicated retail parking garage with 46 spaces, in addition to 20 dedicated office stalls and an additional 47 open stalls throughout the project as well as short term bicycle parking
- Retail & Office space complete & ready to deliver in shell condition



SWC S Delaware St & Concar Ave | SAN MATEO

STATION PARK
GREEN

COMPETITION AERIAL



Caltrain

Philz Coffee
 Pacific Catch
 OrangeTheory Fitness
 Chipotle Mexican Grill

BRIDGEPOINT SHOPPING CENTER
 NORDSTROM RACK
 PETCO
 OLD NAVY
 STAPLES
 TOYS R US
 Marshalls
 BED BATH & BEYOND
 ULTA BEAUTY
TARGET

THE HOME DEPOT

COSTCO WHOLESALE

DOWNTOWN SAN MATEO

Caltrain

SAFeway

CVS/pharmacy
 FITNESS

Sprint
 JO-ANN
 M

Smart & Final
 Specialty's
 Office DEPOT

TRADER JOE'S
 TJ-maxx
 Ross
 Shane Co
 RITE AID

92

82

PERFORMANCE BICYCLE
 FITNESS 19
 at&t

BAY MEADOWS

Alameda De Las Pulgas

ana furniture
 Michaels

HILLSDALE MALL
 macys
 PETS MART
 NORDSTROM
 TRADER JOE'S
 Apple
 UNI QLO
 Guitar Center

Caltrain

WHOLE FOODS
 Habit BURGER GRILL
 Peets Coffee & Tea
 CROUCH

SWC S Delaware St & Concar Ave | SAN MATEO

SITE PLAN

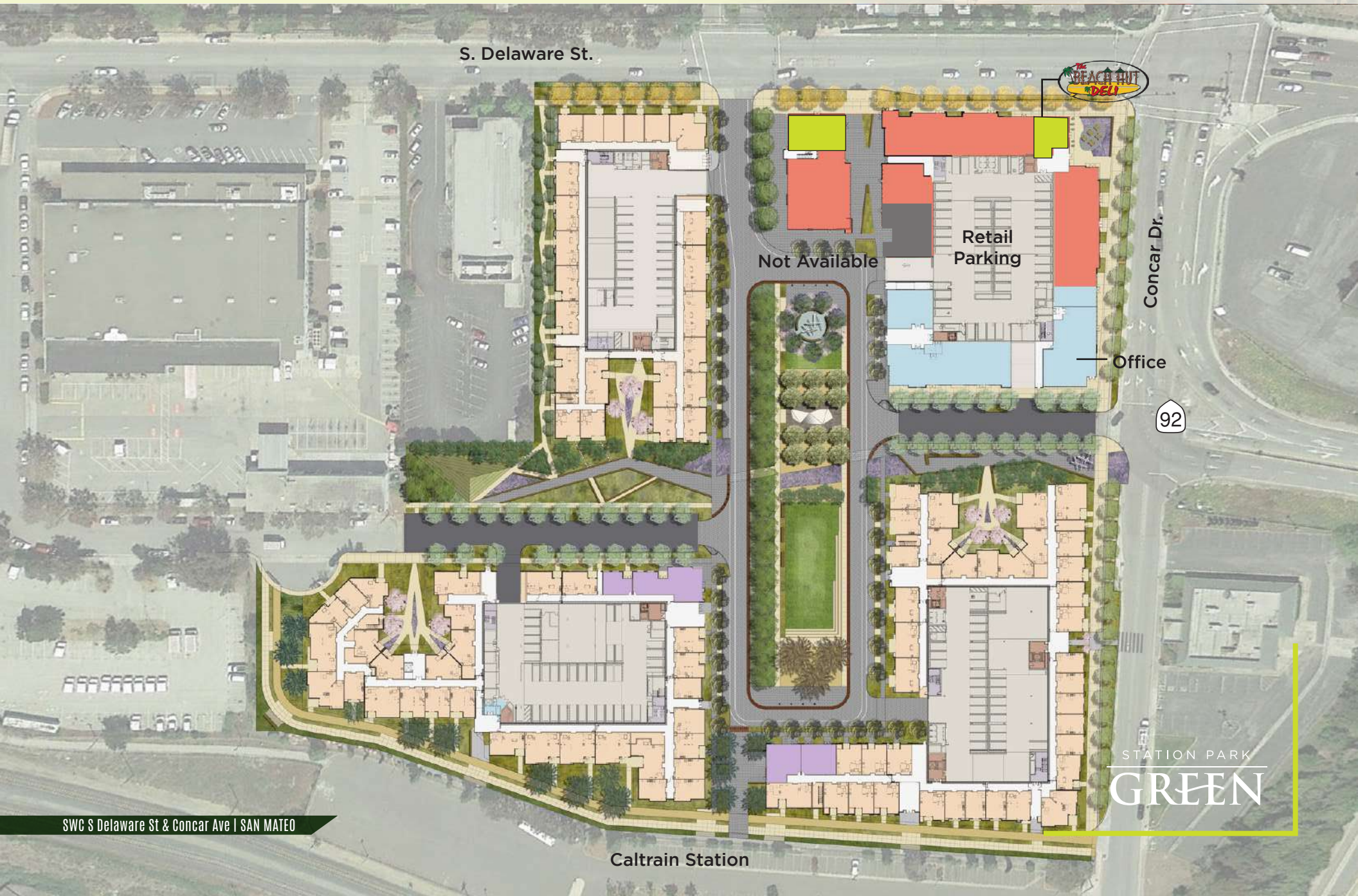

S. Delaware St.



Not Available

Retail Parking

Concar Dr.

Office



Caltrain Station

STATION PARK
GREEN

SWC S Delaware St & Concar Ave | SAN MATEO

FLOOR PLANS

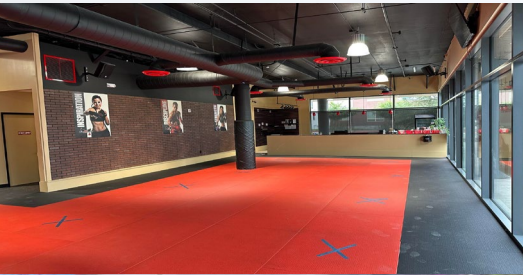
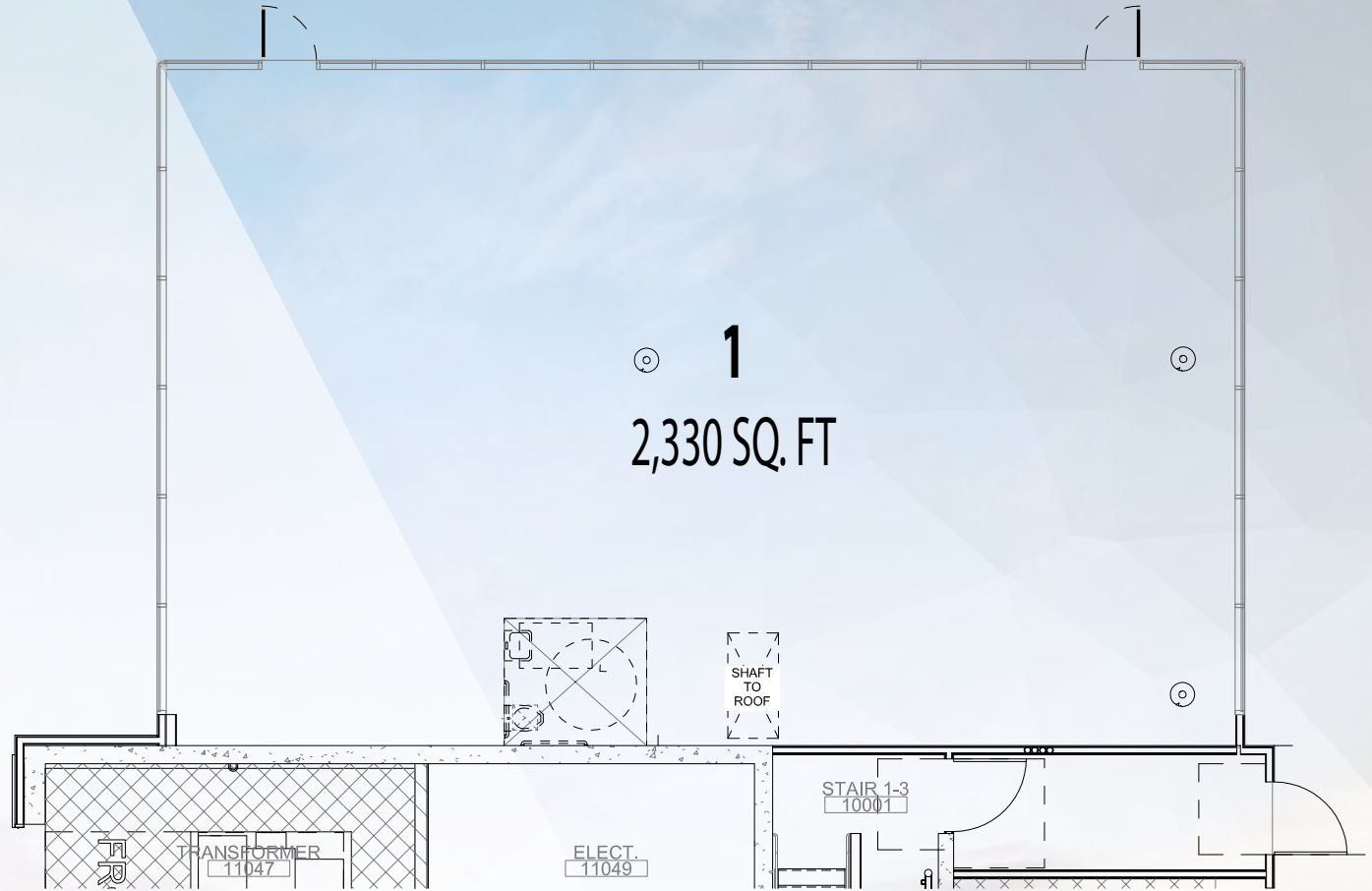
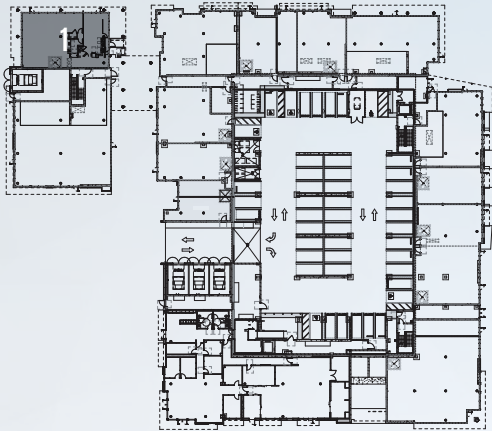

FLOOR PLANS

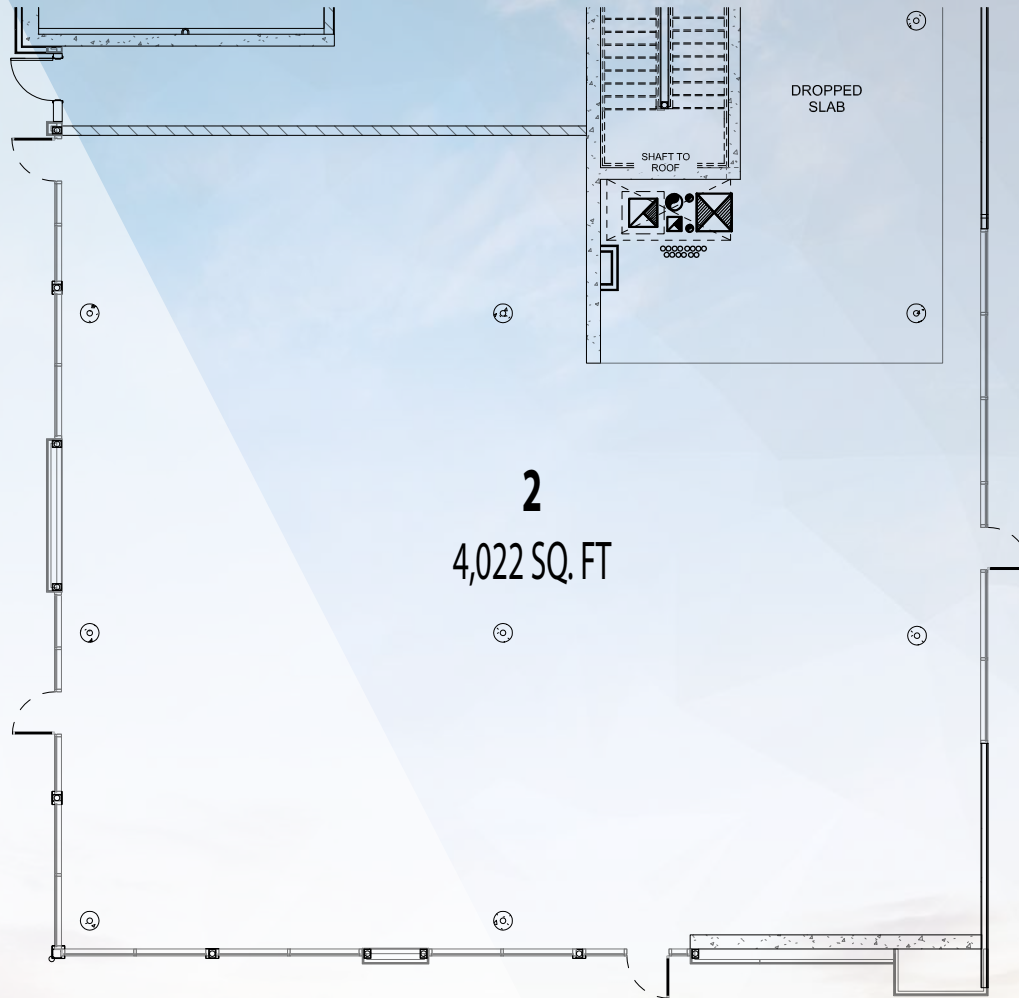
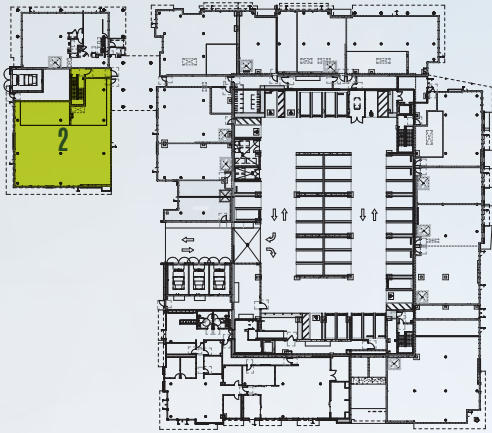

FLOOR PLANS



Available

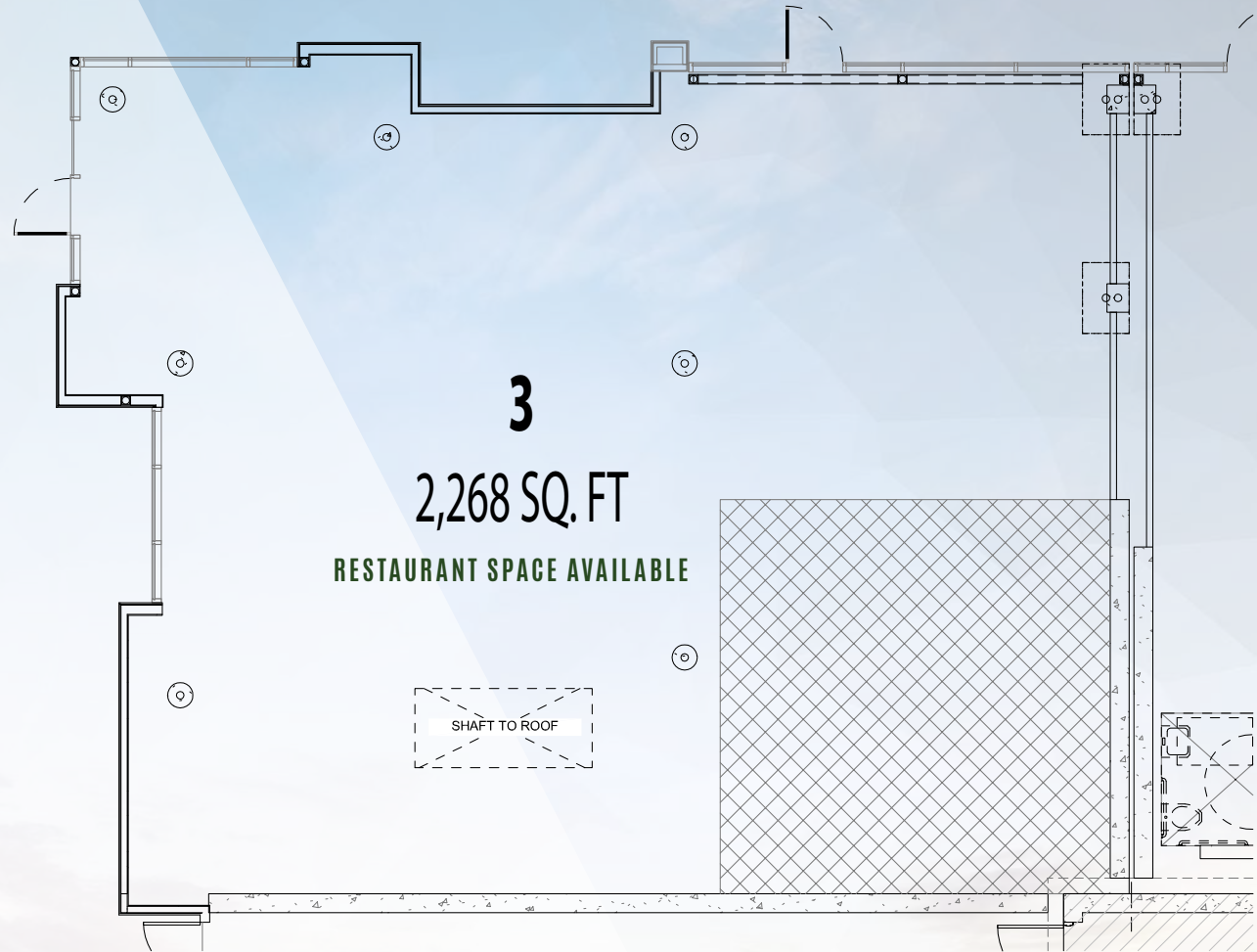
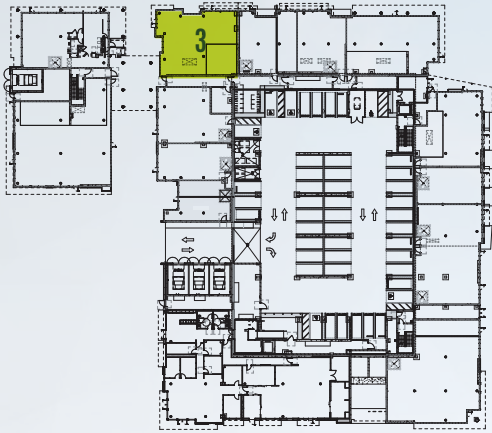

FLOOR PLANS

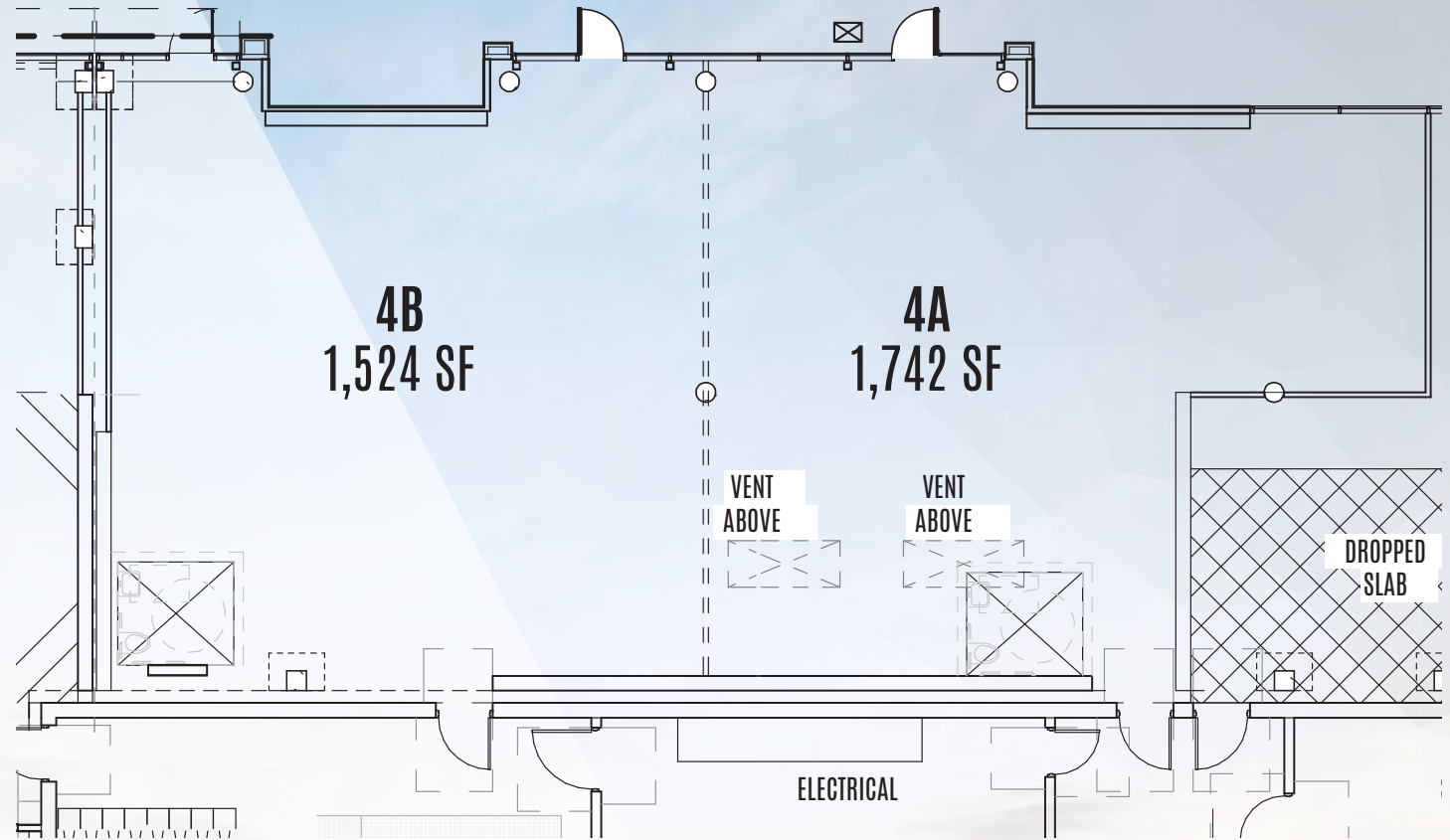
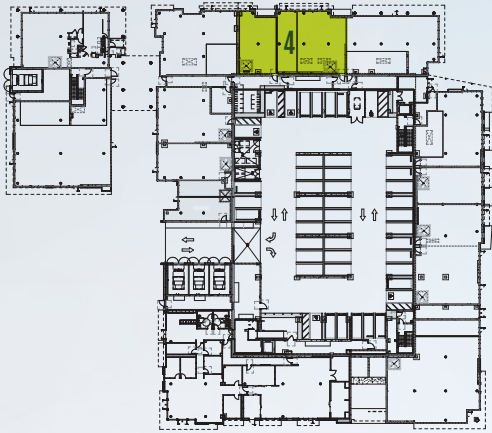

FLOOR PLANS

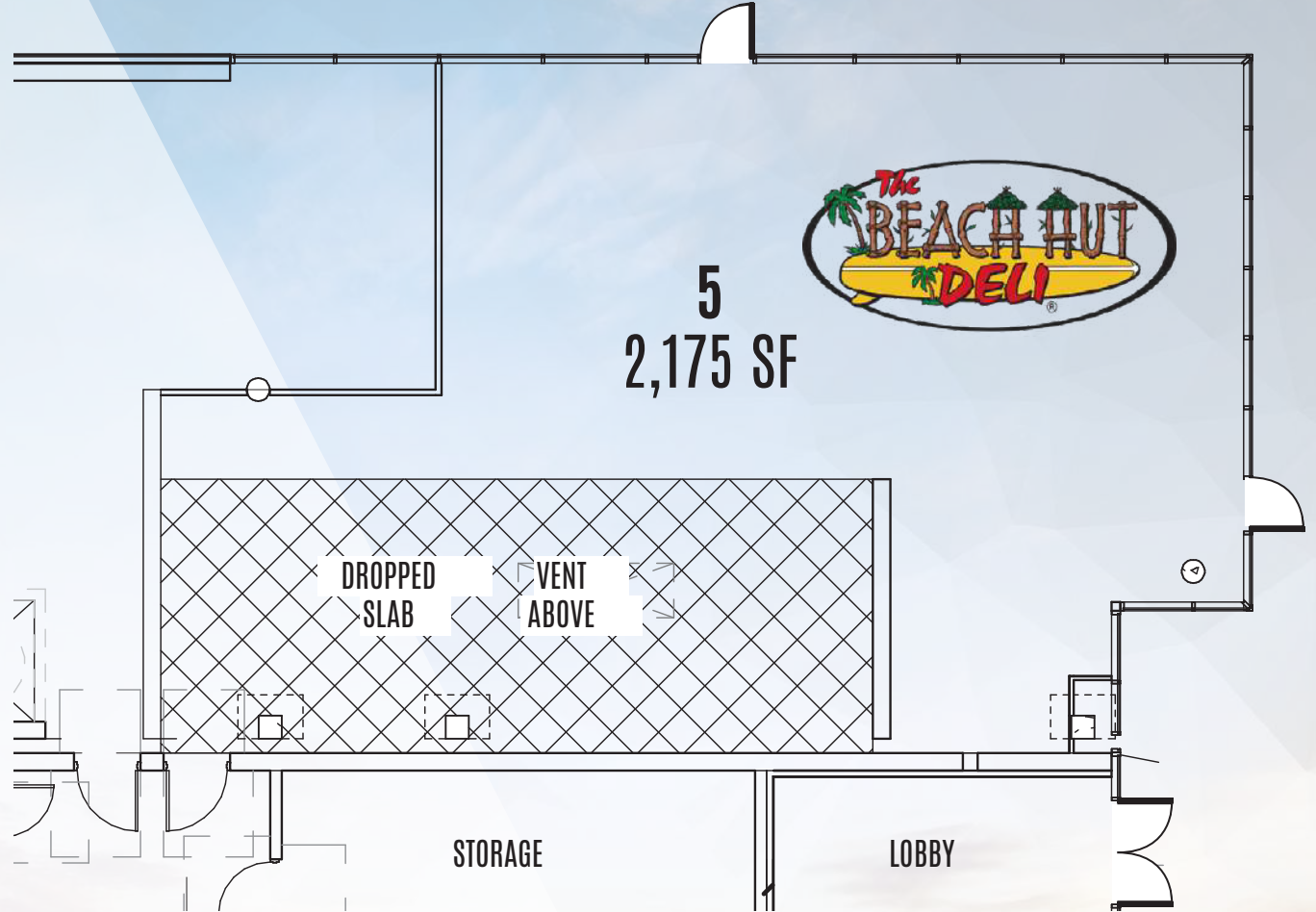
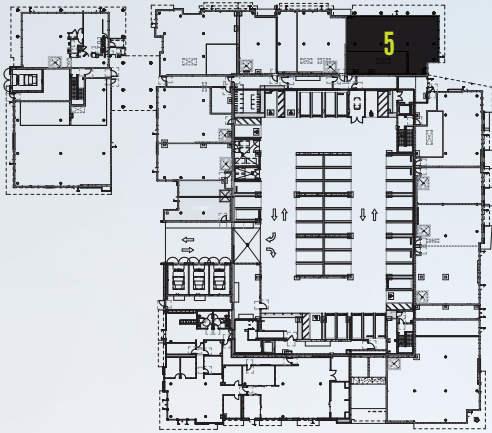

FLOOR PLANS

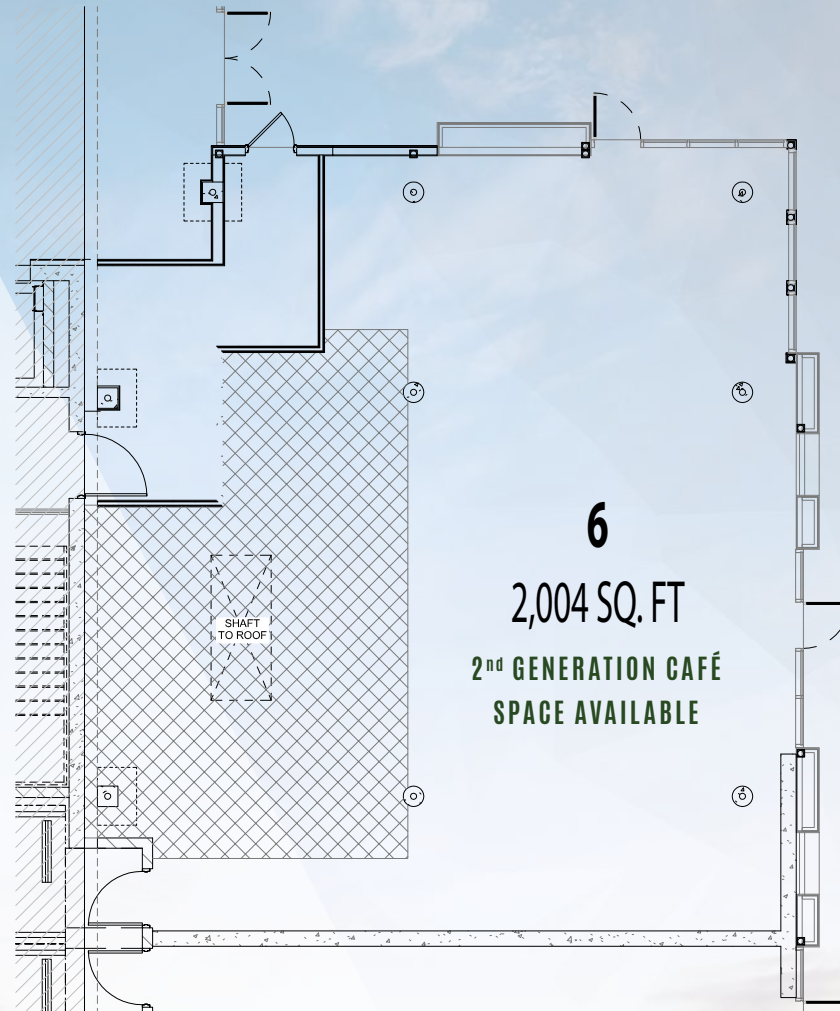
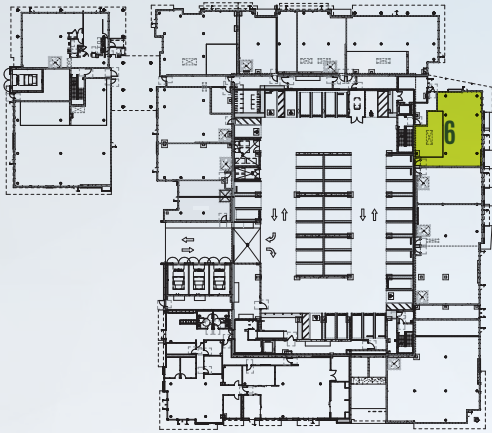

FLOOR PLANS

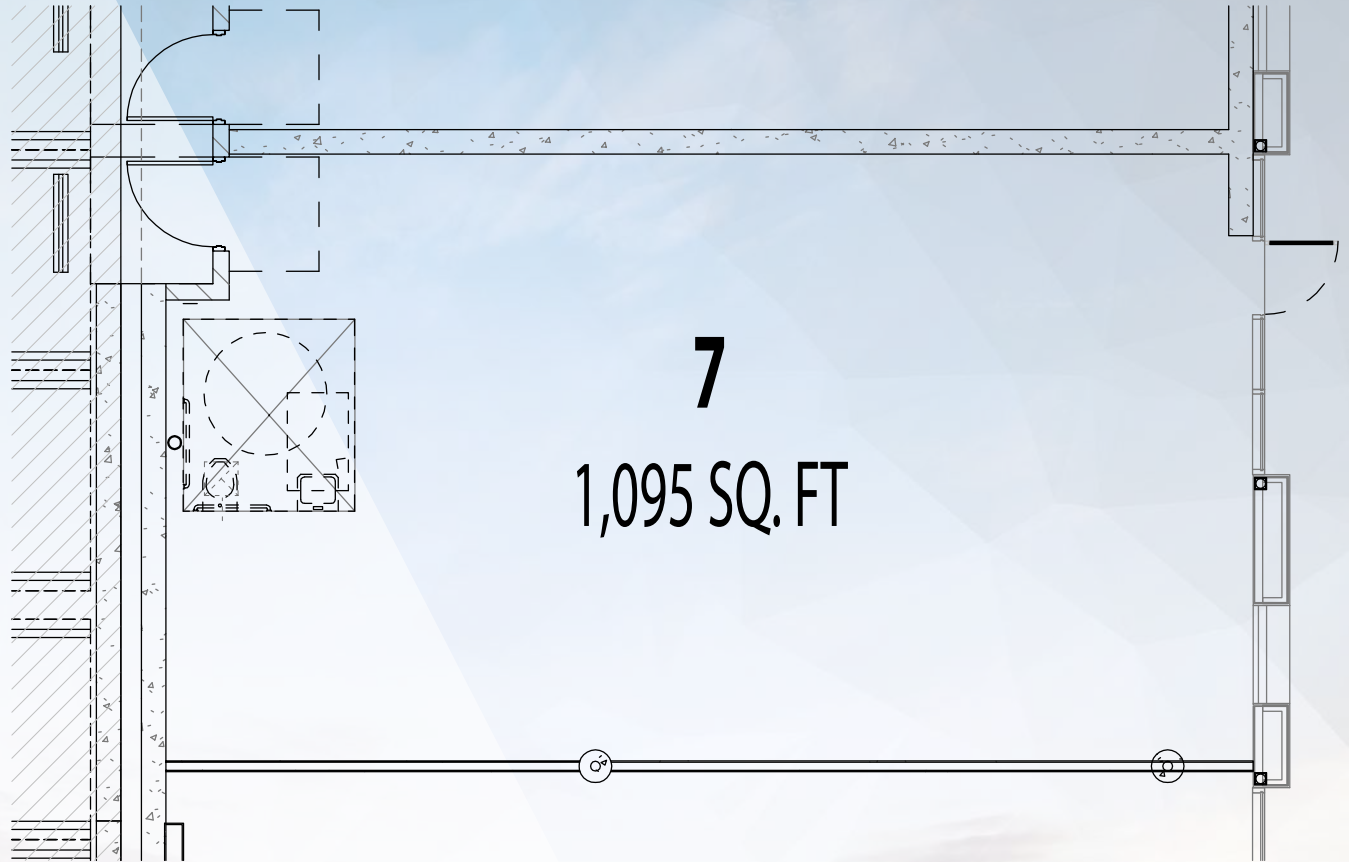

FLOOR PLANS



Office Space

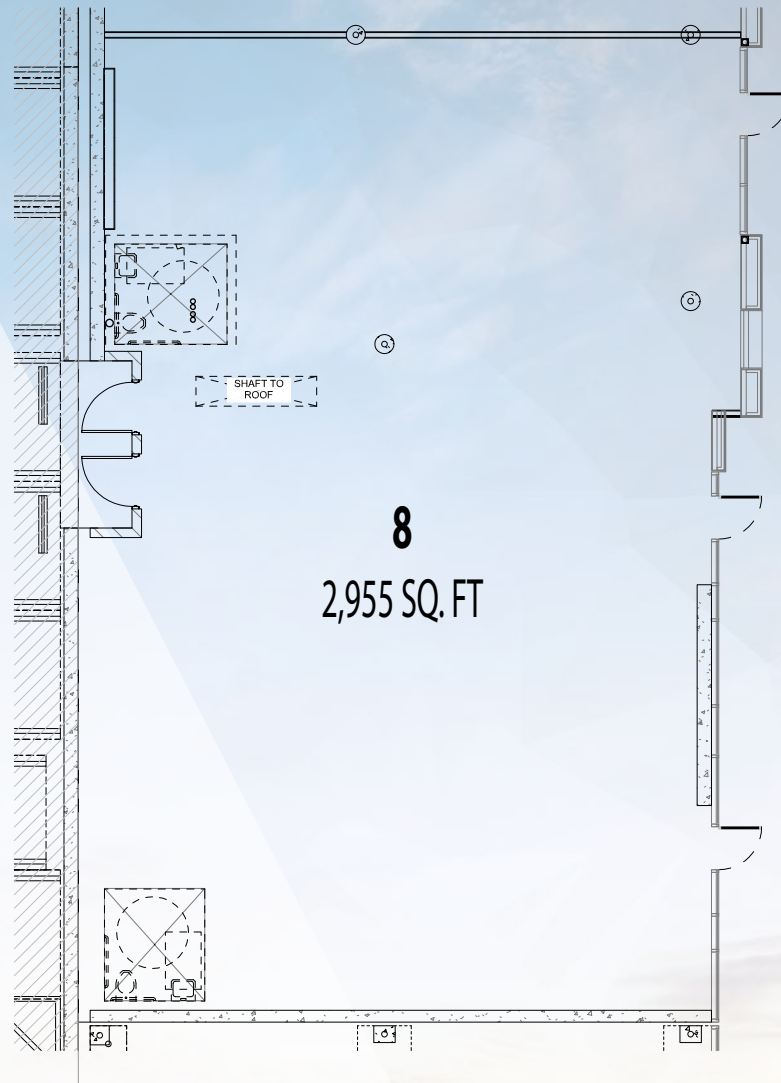
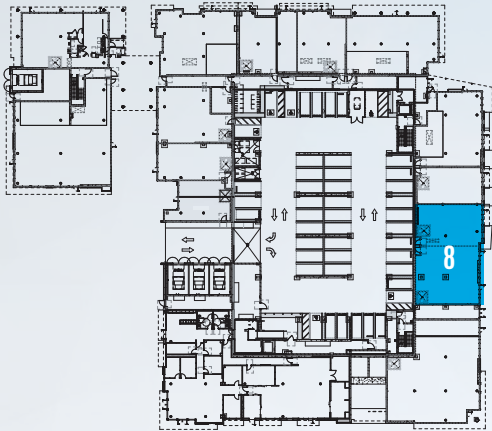

FLOOR PLANS



Office Space

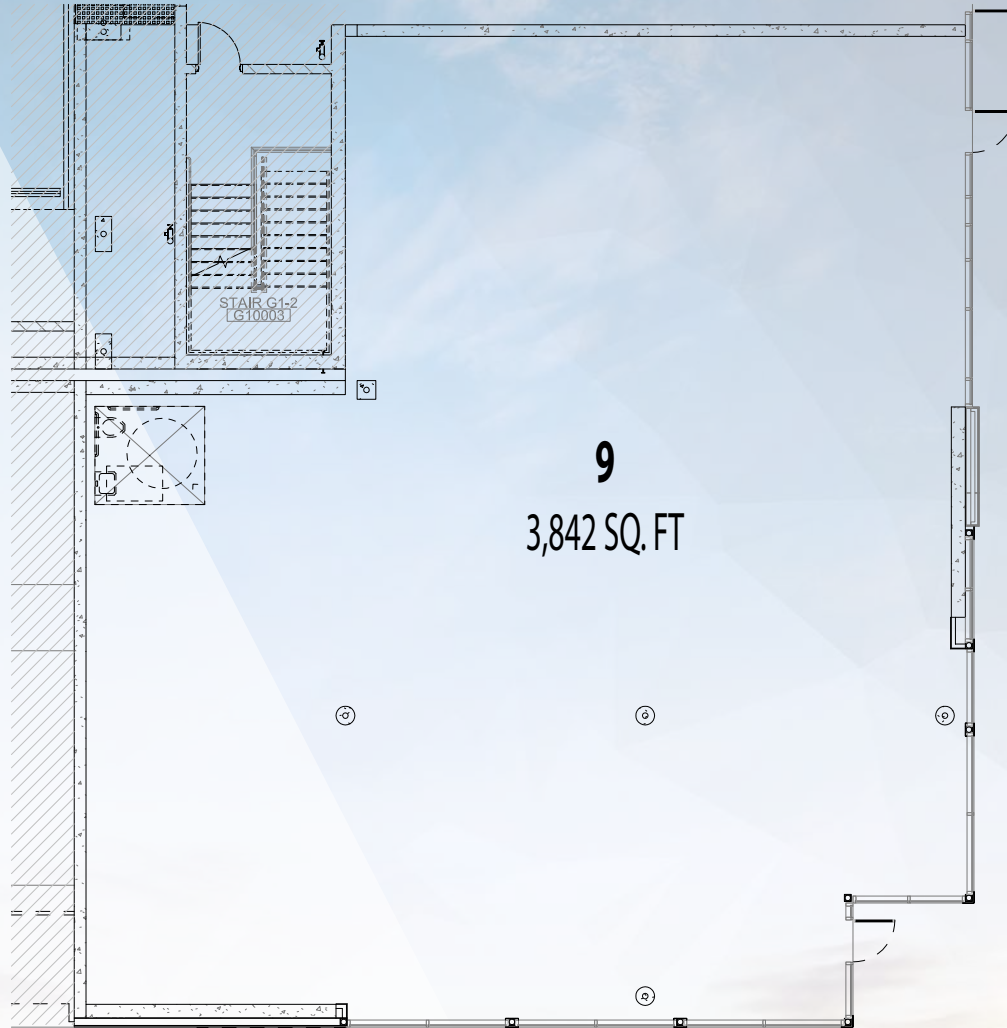
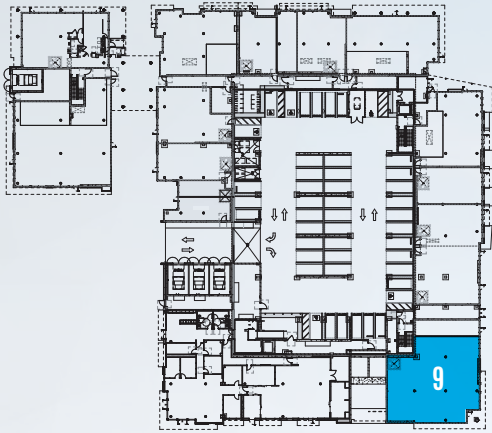

FLOOR PLANS

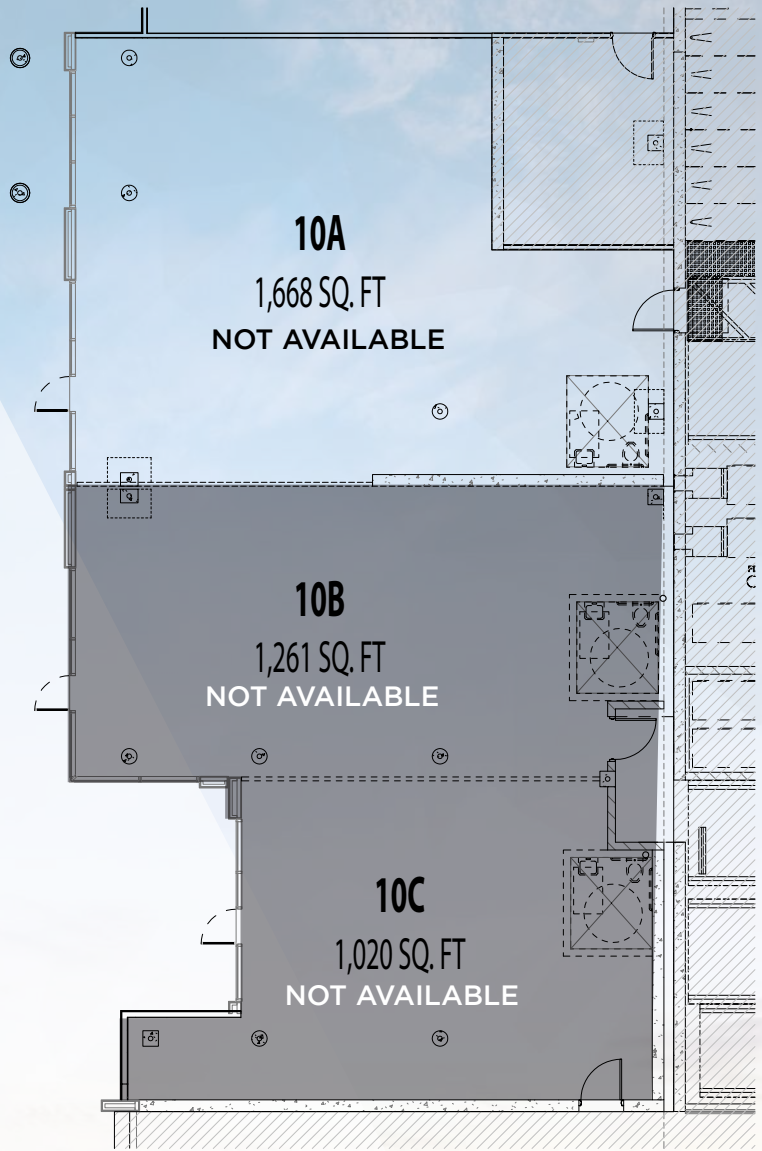
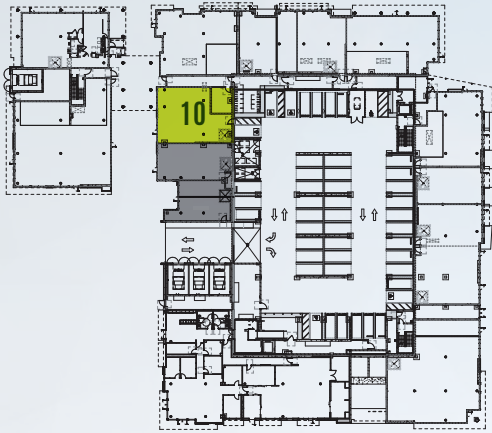

KEY TRAFFIC DRIVERS



KEY TRAFFIC DRIVERS 400/450 CONCAR

PROJECT HIGHLIGHTS

Centrally located at the intersection of Hwy 101 and 92 in San Mateo, 400|450 Concar provides tenants with a rich amenity base adjacent to Station Park Green with 35,000 SF of Class-A retail / commercial space, access to Caltrain and a unique opportunity for highway-oriented tenant signage.

- 305,000 SF Class-A Office Complex
- Available June 2016
- Pre-certified LEED® Platinum
- 20,000 SF Private Second Level Roof Terrace
- Up to 9 Highway-Oriented Signage Opportunities
- Optional 2-Level Bridge Creating Opportunity for 67,000 SF Contiguous Floorplates at 450 Concar
- Secured Garage Parking
- Efficient Floorplates
- Onsite Showers & Bicycle Parking
- Electric Vehicle Charging Stations



DRIVE TIME MAP

DEMOGRAPHICS (2023)	5 Minutes	7 Minutes	10 Minutes
2028 Total Population	36,423	102,455	203,935
2023 Total Population (Estimated)	36,031	100,919	202,061
Total Daytime Population	35,784	94,565	159,547
Median Age	41.8	40.9	41.7
Total Households	14,732	39,134	78,343
Owner Occupied Housing Units	7,281	20,431	42,951
Total % Owner Occupied Housing Units	49.4	52.2	54.8
Average Household Income	196,197	199,077	208,534
Median Household Income	144,631	144,717	153,534
Per Capita Income	\$79,940	\$77,042	\$80,722
Any College	22,224	122,190	224,144
Any College %	85.4	84.5	81.4
% White Collar Occupations	79.8	77.8	79.6
% Blue Collar Occupations	10.2	10.9	9.9
Average Household Size	2.41	2.55	2.54

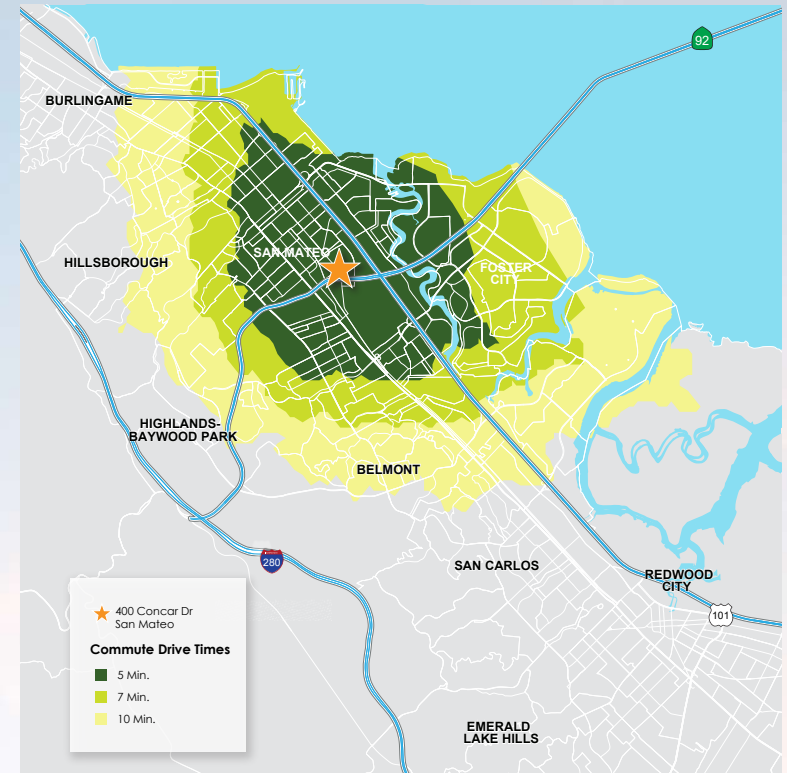

MILEAGE MAP

DEMOGRAPHICS (2023)	1 Mile	3 Miles	5 Miles
2028 Total Population	30,215	173,947	254,572
2023 Total Population (Estimated)	30,028	172,439	251,813
Total Daytime Population	25,157	102,198	165,503
Median Age	41.7	41.7	42.3
Total Households	10,784	64,592	94,482
Owner Occupied Housing Units	6,195	37,129	56,378
Total % Owner Occupied Housing Units	53.8	56.3	58.5
Average Household Income	185,832	210,911	220,883
Median Household Income	136,510	153,647	161,590
Per Capita Income	\$72,133	\$104,155	\$154,813
Any College	17,327	104,155	154,813
Any College %	80.7	84.5	86.3
% White Collar Occupations	75.2	79.3	81.6
% Blue Collar Occupations	11.8	10.2	8.8
Average Household Size	2.55	2.59	2.58



SWC S Delaware St & Concar Ave | SAN MATEO

STATION PARK
GREEN

STATION PARK
GREEN

SWC S Delaware St & Concar Ave
SAN MATEO

New Mixed-Use Development
with 29,000 SF of Ground Floor Retail/Office Space



FOR LEASING INFO CONTACT:

Matt Sweeney

Executive Director

(408) 863-1444

msweeney@theeoniccompany.com

CA RE License #01746896

Sean O'Carroll

Executive Director

(408) 863-1447

socarroll@theeoniccompany.com

CA RE License #01058587

Ron Cruz

Associate

(408) 400-7003

rcruz@theeoniccompany.com

CA RE License #02018499

FOR OFFICE LEASING INFO CONTACT:

Graham Woodall

Executive Managing Director

650.358.5274

graham.woodall@nmrk.com

CA RE License #01396445



© 2023 the eonic company. No warranty or representation, express or implied, is made to the accuracy or completeness of the information contained herein, and same is submitted subject to errors, omissions, change of price, rental or other conditions, withdrawal without notice, and to any special listing conditions imposed by the property owner(s). As applicable, we make no representation as to the condition of the property (or properties) in question.

